

New Paddy Husker

PADDY HUSKER

HR10DD



HR10DD

SATAKE CORPORATION

Satake has incorporated its unique technologies into the New Paddy Husker HR10DD for superior performance.

FEATURES:

1. Dual Drive :

The Paddy Husker incorporates a Dual Drive System. The main and counter shaft speeds can be automatically interchanged.

2. Automatic Adjustment :

The Paddy Husker is equipped with an electronic regulator to ensure peak performance. It automatically adjusts the pressure of the roll air and maintains an optimum husking efficiency.

3. No Roll Reversal :

With the Dual Drive system and Automatic Adjustment, the new husker automatically stabilizes the husking efficiency and the reversal of the rubber rolls during their usable life is no longer necessary.

4. Product lineup of with or without outlet for immature grains:

Models with or without outlet for immature grains are offered according to customer requirement.
 HU10DD + HA10Da = Without outlet for immature grains
 HU10DD + HA10Db = With outlet for immature grains.

5. Easy maintenance and cleaning:

Careful design consideration has been given to ease of maintenance and cleaning. The new paddy husker design minimizes the use of bolts and fasteners.

6. New Design :

Fully automatic, Simple and User-Friendly,

PADDY HUSKER

Specifications

Model	HR10DD
Required Power (kW)	18.9
Input Capacity (t/h on Long Grain)	5~7

*Capacity may differ according to input material and operating conditions.

Dimensions

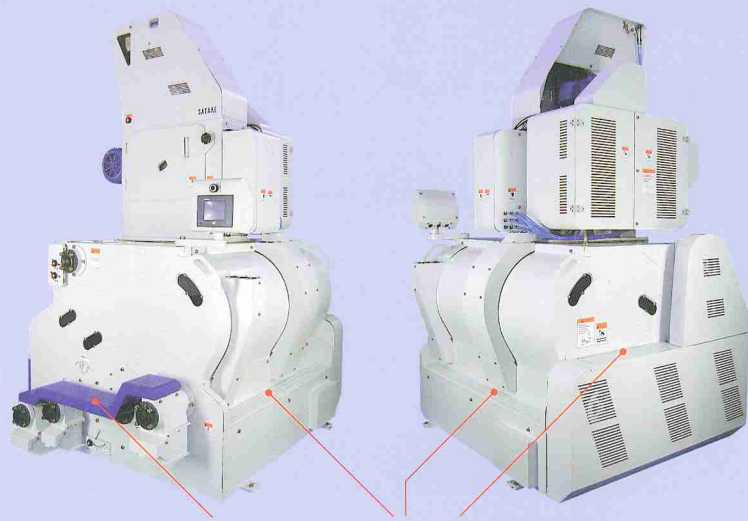
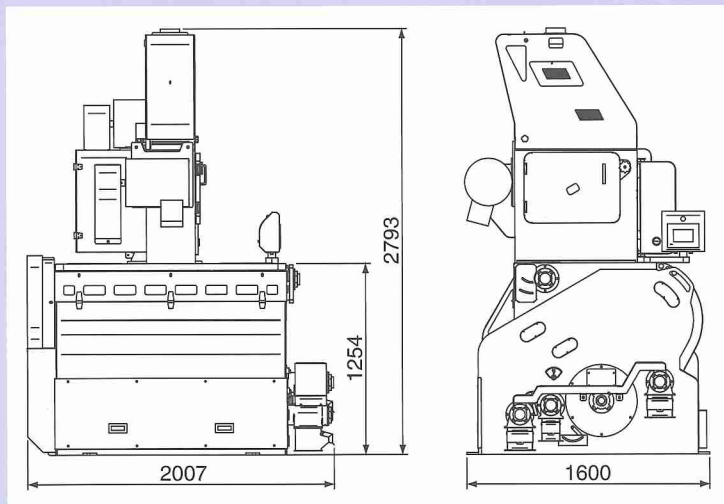

FOOT STEP FOR MAINTENANCE

All Satake products are the subject of continuous development and, as a result, their specification may change and differ in detail from those shown.

SATAKE CORPORATION

Head Office

2-30, Saijo-Nishihonmachi,
 Higashi-Hiroshima, 739-8602, Japan
 Tel : +81-82-420-8560/8539
 Fax : +81-82-420-0865
 e-mail : kg-hiroshima@satake-japan.co.jp
 URL : www.satake-japan.co.jp

UK Division

P.O.Box 53, Bredbury, Stockport,
 Cheshire, SK6 2FG, England
 Tel : +44-161-406-3800
 Fax : +44-161-406-3801
 e-mail : sales@satake.co.uk
 URL : www.satake.co.uk

Yangon Office

No.32, Pyay Road,
 Hlaing Township, Yangon
 Myanmar
 Tel : +95-1-525077
 Fax : +95-1-512742
 e-mail : ygsatake@mptmail.net.mm

Beijing Office

Room 4405, Building No.2,
 No.208, 2nd Zone, Lize
 Zhongyuan, Chaoyang District,
 Beijing, People's Republic of China
 Tel : +86-10-8454-0146
 Fax : +86-10-8454-0145

SATAKE USA INC.

10905 Cash Road,
 Stafford, Texas 77477 U.S.A.
 Tel : +1-281-276-3600
 Fax : +1-281-494-1375
 e-mail : rice@satake-usa.com
 URL : www.satake-usa.com

SATAKE (CANADA) INC.

5100 Fallingbrook Drive
 Mississauga, Ontario, L5V
 1S7, Canada
 Tel : +1-905-858-0791
 Fax : +1-905-858-0957
 e-mail : satakecanada@rogers.com

SATAKE AMERICA LATINA LTDA.

Rua Xavantes, 155-Bairro
 Atiradores, CEP 89203-210,
 Joinville, Santa Catarina, Brazil
 Tel : +55-47-3461-1313
 Fax : +55-47-3461-1300
 e-mail : ricardo@satake.com.br

SATAKE INDIA ENGINEERING PVT. LTD.

4th Floor, Tower-1, HB Twin Towers, A2,
 3, 4-Nelaji Subhash Place, Wazirpur
 District Centre, New Delhi, 110034, India
 Tel : +91-11-41472626
 Fax : +91-11-41472624
 e-mail : satake@del2.vsnl.net.in

SATAKE (THAILAND) CO., LTD.

133 Moo 5, Bangkadi Industrial Park,
 Tivanon Road, Patumthani 12000, Thailand
 Tel : +66-2-501-1180
 Fax : +66-2-501-1188
 e-mail : sataketh@asia.com
 URL : http://www.sataketh.com/

SATAKE INTERNATIONAL BANGKOK CO., LTD.

868/152 Mahatun Plaza Bld. 15th Floor
 Ploenchit Rd., Lumpini Patumwan
 Bangkok 10330, THAILAND
 Tel : +66-2-651-5845
 Fax : +66-2-651-5848
 e-mail : sataketh@asia.com

SATAKE MANUFACTURING (SUZHOU) CO., LTD.

Jin Feng Road, Suzhou
 New District, Suzhou City,
 Jiangsu Province P.R.China
 Tel : +86-512-6536-8225
 Fax : +86-512-6536-5922
 e-mail : satake@satake.cn

SATAKE AUSTRALIA PTY. LTD.

23-25 Marigold Street, Revesby,
 NSW 2212 Australia
 Tel : +61-2-9774-1155
 Fax : +61-2-9774-1248
 e-mail : sataus@ozemail.com.au
 URL : www.satake.com.au

SATAKE CORPORATION has
 obtained ISO 9001 and ISO
 14001 certification.
 These international standards
 for management systems
 ensure Satake will continue to
 provide high quality products
 and services.

ISO 9001 Certification
 (Quality Management Systems)
 ISO 14001 Certification
 (Environmental Management Systems)