

High Capacity Milling Separator

MILLING SEPARATOR

SFI1000A / SFI1500A

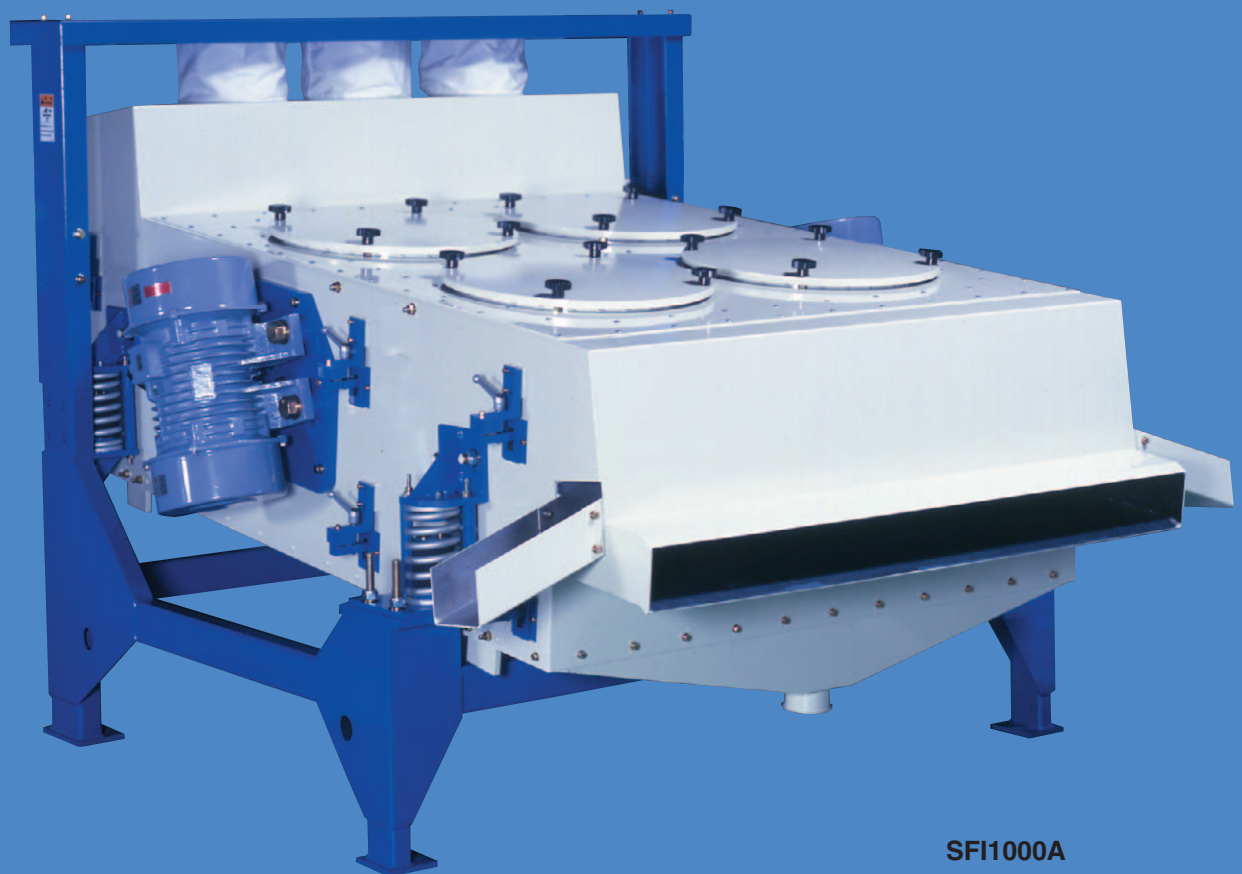

SFI1000A

The Satake Milling Separator SFI is an all purpose separator for the cleaning of cereal grains, such as wheat, rice, maize (corn), rye, oats, etc. The oscillation of the double deck sieves efficiently removes both large or coarse material, and fine impurities from the grain being cleaned.

The SFI is available as a Silo (elevator) Intake Separator for high capacities and as a Milling Separator, to provide a more precise separation.

The SFI can be used with a simple exhaust or can be matched to either a SCA Closed Circuit Aspirator or an open circuit aspirator.

FEATURES:

- High separating efficiency.
- Large capacity.
- Robust construction with low maintenance requirements.
- Easy sieve removal.
- Easy inspection cover removal.
- Simple and precise motor alignment.

MILLING SEPARATOR

Specifications

Model		SFI1000A	SFI1500A
Capacity (t/hr)*	Intake	65	100
	Cleaning	16	24
Motor (kW-p)		0.85-6 x 2	1.6-6 x 2
Suction	(m ³ / min.)	12	
	(kPa)	-0.2 ~ -0.1	

* The capacity quoted is for the wheat of 78kg/hl, 15.0% moisture content and 3.0% impurities. For other applications, please refer to the Satake Technical Division for advice.

Dimensions

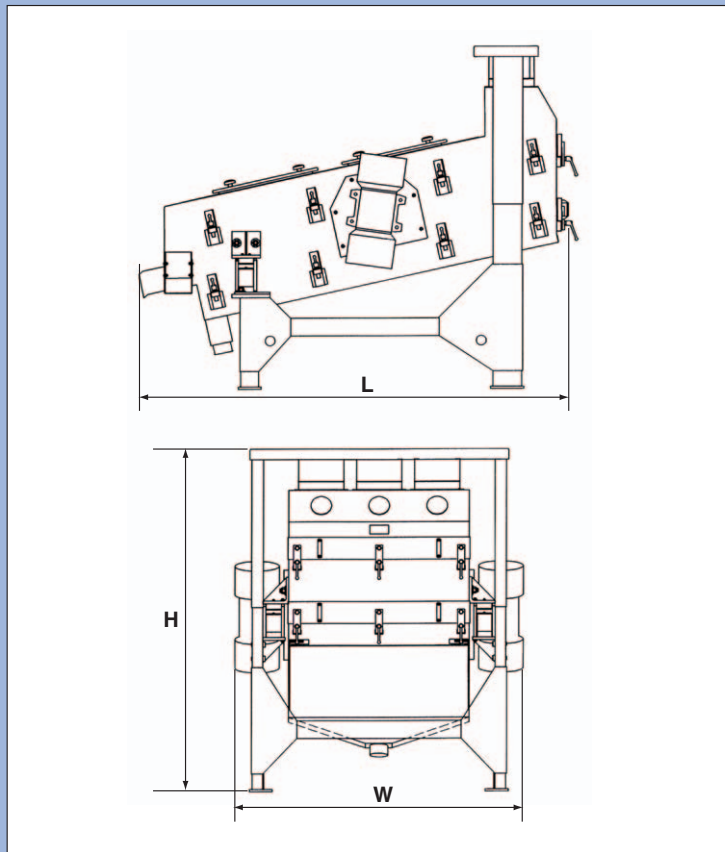

Model	W(mm)	L(mm)		H(mm)		Net Weight (kg)
		Intake	Cleaning	Intake	Cleaning	
SFI1000A	1,616	2,420	2,339	1,933	1,768	1,000
SFI1500A	2,236					1,500

All Satake products are the subject of continuous development and, as a result, their specification may change and differ in detail from those shown.

SATAKE CORPORATION is registered with ISO9001 standards for quality management systems and ISO14001 standards for environmental management systems.



SATAKE CORPORATION

Head Office
2-30, Saijo-Nishihonmachi,
Higashi-Hiroshima, 739-8602, Japan
Tel : +81-824-20-8560/8539
Fax : +81-824-20-0865
e-mail : kg-hiroshima@satake-japan.co.jp
URL : www.satake-japan.co.jp

UK Division
P.O.Box 53, Bredbury, Stockport,
Cheshire, SK6 2FG, England
Tel : +44-161-406-3800
Fax : +44-161-406-3801
e-mail : sales@satake.co.uk
URL : www.satake.co.uk

New Delhi Office
11th Floor, Dr. Gopal Das Bhaven,
28 Barakhamba Road, New Delhi
110001 India
Tel : +91-11-3738646
Fax : +91-11-3738647

Beijing Office
Room 203B, Chang Xin Building,
No.39 An Ding Road,Chao Yang
District,Beijing, P.R.China
Tel : +86-10-6443-3822
Fax : +86-10-6443-4188

Bangkok Office
133 Moo 5, Bangkadi Industrial Park
Tivanon, Road, Patumthani 12000
Thailand
Tel : +66-2-501-1223
Fax : +66-2-501-1225
e-mail : sataketh@asia.com

Yangon Office
No.4 Kanthaya Street,
South Okkalapa Township, Yangon
Myanmar
Tel : +95-1-578303
Fax : +95-1-570610



SATAKE USA INC.
9800 Townpark,
Houston, Texas 77036 U.S.A.
Tel : +1-713-772-8400
Fax : +1-713-772-8484
e-mail : rice@satake-usa.com
URL : www.satake-usa.com

SATAKE AUSTRALIA PTY. LTD.
23-25 Marigold Street, Revesby,
NSW 2212 Australia
Tel : +61-2-9774-1155
Fax : +61-2-9774-1248
e-mail : sataus@ozemail.com.au
URL : www.satake.com.au

SATAKE (THAILAND) CO., LTD.
133 Moo 5, Bangkadi Industrial Park
Tivanon Road, Patumthani 12000
Thailand
Tel : +66-2-501-1180
Fax : +66-2-501-1188
e-mail : sataketh@asia.com

SATAKE MANUFACTURING (SUZHOU) CO., LTD.
Jin Feng Road, Suzhou
New District, Suzhou City,
Jiangsu Province P.R.China
Tel : +86-512-6536-8225
Fax : +86-512-6536-3004
URL : www.satake-suzhou.com.cn

SATAKE (CANADA) INC.
2550 Argentia Road, Suite 119
Mississauga, Ontario
L5N 5R1 Canada
Tel : +1-905-858-0791
Fax : +1-905-858-0957

SATAKE AMERICA LATINA LTDA.
Conjunto Empresarial Joinville
Rua Xavantes, 155-Bairro
Atradores 89203-210-Joinville-
Santa Catarina, Brazil
Tel : +55-47-438-0413
Fax : +55-47-438-7932
e-mail : ricardo@satake.com.br