SATAKE TESTING HUSKER



FOREMOST IN THE GRAIN WORLD
SATAKE CORPORATION

Satake Testing Husker, model THU35B, is designed to provide rapid, accurate results in determining husking yields. It is manufactured to meet the requirements of laboratories, research and educational institution.

FEATURES

1. Rubber Roll Type Husker

Because of the large diameter rubber roll used, it is easy to obtain a high and uniform husking ratio.

2. Easy Operation

The operation is easy and quiet.

3. Husking Condition Can Be Seen

From the outside you can confirm the husking condition.

4. Easy Carrying

Lightweight construction facilitates transportation of the machine.

5. Built-in Aspirator

Brown rice, husks and immature are separated automatically by a built-in aspirator.

SPECIFICATIONS

Model	THU35B	
Capacity (on paddy)	50 kg/hr.	
Built-in motor	AC 230V, single phase, 400W	
Revolution	Main shaft	1,900 rpm
	Movable shaft	1,000 rpm
Size of rubber roll	Width 35 x Dia. 100 mm	
Dimensions	700 (L) x 310 (W) x 750 (H) mm	
Weight	Net	32 kg
	Gross	Approx. 55 kg
Measurement	Approx. 0.25 m ³	
Accessories	Nylon brush: 1 pc. Spanner: 1 pc.	

*Specifications subject to change without notice.

**For order, please specify electric specifications.

CONSTRUCTION

- A sample of paddy to be tested is placed in the hopper.
- Opening the shutter allows the sample to flow into the machine passing the adjustable flow regulation valve.
- The paddy is husked into brown rice as it passes between the counter rotating rubber rolls of different peripheral speeds.
- The brown rice and immature are separately discharged into receptacles. The husk is aspirated by the fan and is collected in a receptacle after passing through the cyclone.

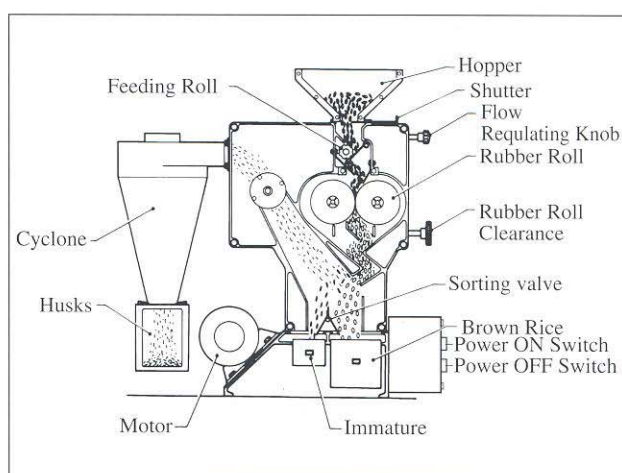

DIMENSION

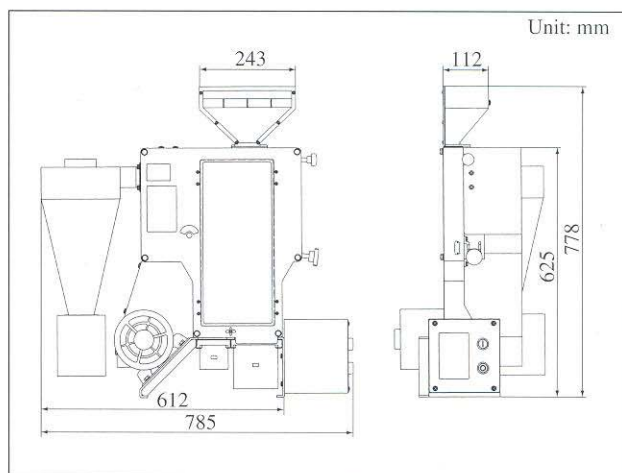

Since 1896

CAT NO. VII-3-(2)

SATAKE CORPORATION

2-30, Saijo Nishihonmachi, Higashihiroshima-shi
Hiroshima 739-8602, Japan
Tel: 81-824-20-8539 Fax: 81-824-20-0865
E-mail : JDG02056@nifty.ne.jp